



# Drillers Mud Systems, LLC

P. O. Box 61340, Lafayette, Louisiana 70596

Tel: (337) 288-4809 fax: (337) 988-3411



## 2350-HDD

Triplex Piston Pump



### 2350 HDD Pump Package Providing the following features:

- ▶ Small Foot Print 18' X 8'. Light weight package 16,500 pounds.
- ▶ High output: over 600 Gallons Per Minute @ over 600 PSI continuous duty cycle.
- ▶ 75' Drillers remote to operate engine RPM, charge pump on/off, 6" 0-3000 PSI pump gauge and pump on/off.
- ▶ On board JoBox Tool Box with tools, pump spares, engine fuel filters and 2350 HDD operations manual.
- ▶ Pressure relief valve set at 2300PSI, 0-3000 PSI pump Gauge on pump and 5 gallon pulsation dampeners.
- ▶ 20 GPM electric liner lubrication system with oil pressure on/off switch with extra pump in JoBox.
- ▶ 8V71 275HP Detroit diesel engine w/ noise attenuation muffler system. On board tachometer/ hour gauge.
- ▶ 2" Enviromental drip pan around entire skid with 2" NPT drains.
- ▶ Rolling tail board loading hitch and 4 pad-eye lifting hitches.
- ▶ 80 Gallon DOT approved diesel fuel tank
- ▶ 250 PSI stainless steel filter assembly plumbed into the suction inlet of mud pump. Quick Clean Out cap.
- ▶ 120 PSI air system with air volume tank and air pressure gauge at drillers remote.
- ▶ A 4.091 to 1 ratio planetary gear box to provide streamlined assembly with over 13020 Ft/Lbs of continous torque.



# Drillers Mud Systems, LLC

P. O. Box 61340, Lafayette, Louisiana 70596

Tel: (337) 288-4809 fax: (337) 988-3411



## Weatherford®

Industrial Pumps

# 2350-HDD

Triplex Piston Pump

### Specifications:

<b>Stroke Length: in. (mm)</b>	7	(175)
<b>Maximum discharge working pressure: psi (bar)</b>		
Piston Diameter		
6"	900	(62)
5-1/2"	1100	(76)
5"	1200	(83)
<b>Oil Capacity: gallons (liters)</b>		
Crankcase	7.5	(28.4)
<b>Weight: lbs. (kg)</b>		
Pump only	6000	(2721)
<b>Optional Accessories:</b>		
Packing flush		
Positive crankcase lubrication		

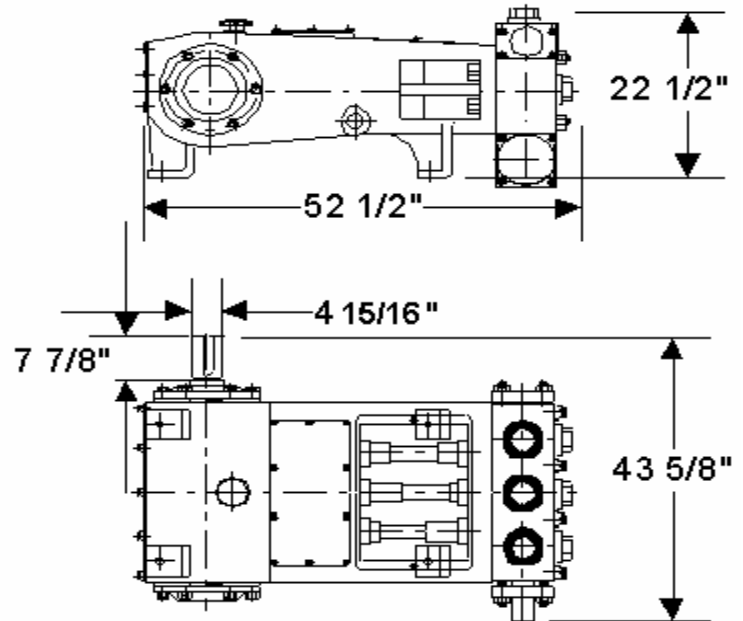

**NOTE:** Dimensional information provided as a reference only.  
Please consult factory for certified drawings.

### Features:

#### Drive-End:

<i>Main Bearings</i>	Steel tapered roller bearing with 30,000 hour design life.
<i>Power Frame</i>	Cast iron
<i>Crank Shaft</i>	Forged steel
<i>Rod Bearings</i>	Replaceable insert
<i>Connecting Rod</i>	Cast steel
<i>Forced Lubrication</i>	Allows for low speed operation.

#### Fluid End:

<i>Fluid Cylinder</i>	Forged
<i>Valving</i>	Valve access through single point for ease of maintenance.
<i>Connection Ports</i>	Bolt on suction and discharge connection in both threaded and flange arrangement. Allows flexibility in system packaging.

2350-HDD

Piston Dia. (mm)	Piston Dia. (in.)	Piston Area (mm <sup>2</sup> )	Piston Area (in <sup>2</sup> )	LPR	GPR	Max Pres. psi	100 RPM		150 RPM		200 RPM		250 RPM		300 RPM	
							LPM	GPM	LPM	GPM	LPM	GPM	LPM	GPM	LPM	GPM
152	6	18146	28.27	9.577	2.530	900	958	253	1437	380	1915	506	2394	633	2873	759
140	5 1/2	15394	23.76	8.047	2.126	1100	805	213	1207	319	1609	425	2012	531	2414	638
130	5	13273	19.64	6.651	1.757	1200	665	176	998	264	1330	351	1663	439	1995	527

### CONTACTS:

**Wiley Brice**  
(337) 288-4809  
[wileybrice@aol.com](mailto:wileybrice@aol.com)

or

**Tony Clark**  
(337) 349-2925  
[coatit1309@aol.com](mailto:coatit1309@aol.com)